

# TWIN HOOK MONORAIL HOIST

## 1 TO 3 TON (SINGLE REEVED)

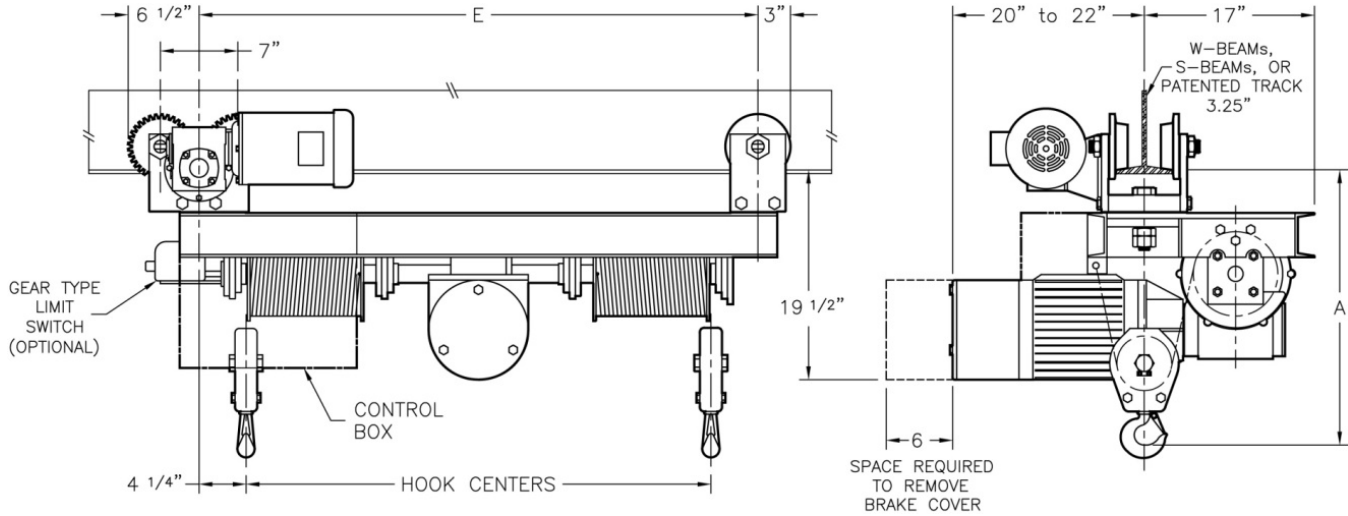

DIMENSIONS FOR REFERENCE

### TRUE VERTICAL LIFT (WITH EQUAL HOOK LOADS)

### STANDARD TROLLEY SPEEDS: 35 & 60 FPM

CATALOG NO.	CAPACITY (LBS)	SPEED (FPM)	LIFT (FT)	REEVING TYPE	CABLE (DIA)	HOIST MOTOR (HP @ RPM)	HEADRM (A)	WHEEL BASE (MIN)	HOOK CENTERS (MIN)	WEIGHT (LBS)
EB2-2022-MT	2,000	20	22	2PS	1/4	2 @ 1200	25"	39 1/2"	31"	1000
EB2-2036-MT	2,000	20	36	2PS	1/4	2 @ 1200	25"	49 1/2"	41"	1100
EB2-2050-MT	2,000	20	50	2PS	1/4	2 @ 1200	25"	59 1/2"	51"	1200
EB2-3022-MT	2,000	30	22	2PS	1/4	3 @ 1800	25"	39 1/2"	31"	1000
EB2-3036-MT	2,000	30	36	2PS	1/4	3 @ 1800	25"	49 1/2"	41"	1100
EB2-3050-MT	2,000	30	50	2PS	1/4	3 @ 1800	25"	59 1/2"	51"	1200
EB3-2022-MT	3,000	20	22	2PS	1/4	3 @ 1200	25"	39 1/2"	31"	1000
EB3-2036-MT	3,000	20	36	2PS	1/4	3 @ 1200	25"	49 1/2"	41"	1100
EB3-2050-MT	3,000	20	50	2PS	1/4	3 @ 1200	25"	59 1/2"	51"	1200
EB3-3022-MT	3,000	30	22	2PS	1/4	5 @ 1800	25"	39 1/2"	31"	1000
EB3-3036-MT	3,000	30	36	2PS	1/4	5 @ 1800	25"	49 1/2"	41"	1100
EB3-3050-MT	3,000	30	50	2PS	1/4	5 @ 1800	25"	59 1/2"	51"	1200
EB4-1011-MT	4,000	10	11	4PS	1/4	2 @ 1200	26"	39 1/2"	31"	1050
EB4-1518-MT	4,000	15	18	4PS	1/4	3 @ 1800	26"	49 1/2"	41"	1150
EB4-1525-MT	4,000	15	25	4PS	1/4	3 @ 1800	26"	59 1/2"	51"	1250
EB4-1532-MT	4,000	15	32	4PS	1/4	3 @ 1800	26"	69 1/2"	61"	1350
EB4-1539-MT	4,000	15	39	4PS	1/4	3 @ 1800	26"	79 1/2"	71"	1450
FB4-2022-MT	4,000	20	22	2PS	1/4	5 @ 1200	29"	42"	33"	1225
FB4-2036-MT	4,000	20	36	2PS	1/4	5 @ 1200	29"	52"	43"	1325
FB4-3036-MT	4,000	30	36	2PS	1/4	7-1/2 @ 1800	29"	52"	43"	1325
FB4-3050-MT	4,000	30	50	2PS	1/4	7-1/2 @ 1800	29"	62"	53"	1425
EB6-1011-MT	6,000	10	11	4PS	1/4	3 @ 1200	26"	39 1/2"	31"	1050
EB6-1518-MT	6,000	15	18	4PS	1/4	5 @ 1800	26"	49 1/2"	41"	1150
EB6-1525-MT	6,000	15	25	4PS	1/4	5 @ 1800	26"	59 1/2"	51"	1250
EB6-1532-MT	6,000	15	32	4PS	1/4	5 @ 1800	26"	69 1/2"	61"	1350
EB6-1539-MT	6,000	15	39	4PS	1/4	5 @ 1800	26"	79 1/2"	71"	1450
FB6-2022-MT	6,000	20	22	2PS	5/16	6 @ 1200	29"	42"	33"	1225
FB6-2036-MT	6,000	20	36	2PS	5/16	6 @ 1200	29"	52"	43"	1325
FB6-3036-MT	6,000	30	36	2PS	5/16	10 @ 1800	29"	52"	43"	1325
FB6-3050-MT	6,000	30	50	2PS	5/16	10 @ 1800	29"	62"	53"	1425

COMMON MODELS WITH MOTORIZED TROLLEY (MT) ONLY ABOVE – OTHERWISE BUILD TO ORDER