

SINGLE HOOK MONORAIL HOIST
4 TO 7.5 TON (4-PART SINGLE REEVED/STANDARD HEADROOM)

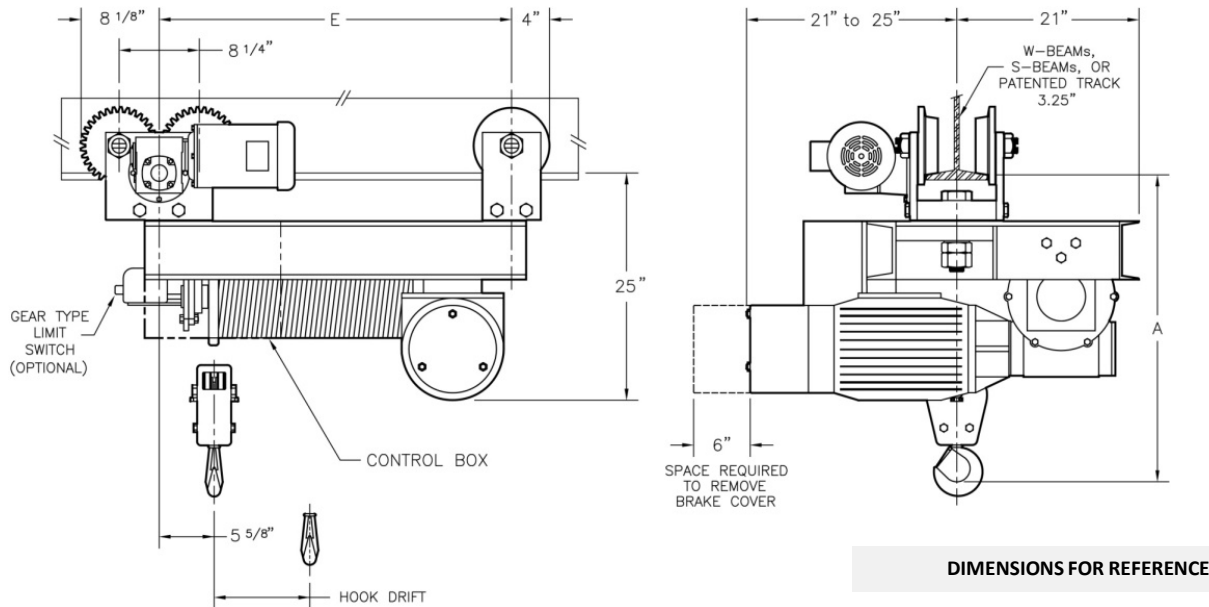

LONGER LIFTS AS CUSTOM

STANDARD TROLLEY SPEEDS: 35 & 60 FPM

CATALOG NO.	CAPACITY (LBS)	SPEED (FPM)	LIFT (FT)	REEVING TYPE	CABLE (DIA)	HOIST MOTOR (HP @ RPM)	HEADROOM (A)	WHEEL BASE (E)	HOOK DRIFT	WEIGHT (LBS)
FA8-1010-MT	8,000	10	10	4PS	3/8	5 @ 1200	37"	28 3/4"	2 3/4"	1175
FA8-1017-MT	8,000	10	17	4PS	3/8	5 @ 1200	37"	36 1/4"	4 1/2"	1250
FA8-1024-MT	8,000	10	24	4PS	3/8	5 @ 1200	37"	43 3/4"	6 1/4"	1325
FA8-1031-MT	8,000	10	31	4PS	3/8	5 @ 1200	37"	51 1/4"	7 7/8"	1400
FA8-1517-MT	8,000	15	17	4PS	3/8	7 1/2 @ 1800	37"	36 1/4"	4 1/2"	1250
FA8-1524-MT	8,000	15	24	4PS	3/8	7 1/2 @ 1800	37"	43 3/4"	6 1/4"	1325
FA8-1531-MT	8,000	15	31	4PS	3/8	7 1/2 @ 1800	37"	51 1/4"	7 7/8"	1400
FA8-1539-MT	8,000	15	39	4PS	3/8	7 1/2 @ 1800	37"	58 3/4"	9 5/8"	1475
FA8-1546-MT	8,000	15	46	4PS	3/8	7 1/2 @ 1800	37"	66 1/4"	11 1/4"	1550
FA10-1010-MT	10,000	10	10	4PS	3/8	6 @ 1200	37"	28 3/4"	2 3/4"	1200
FA10-1017-MT	10,000	10	17	4PS	3/8	6 @ 1200	37"	36 1/4"	4 1/2"	1275
FA10-1024-MT	10,000	10	24	4PS	3/8	6 @ 1200	37"	43 3/4"	6 1/4"	1350
FA10-1031-MT	10,000	10	31	4PS	3/8	6 @ 1200	37"	51 1/4"	7 7/8"	1425
FA10-1517-MT	10,000	15	17	4PS	3/8	10 @ 1800	37"	36 1/4"	4 1/2"	1275
FA10-1524-MT	10,000	15	24	4PS	3/8	10 @ 1800	37"	43 3/4"	6 1/4"	1350
FA10-1531-MT	10,000	15	31	4PS	3/8	10 @ 1800	37"	51 1/4"	7 7/8"	1425
FA10-1539-MT	10,000	15	39	4PS	3/8	10 @ 1800	37"	58 3/4"	9 5/8"	1500
FA10-1546-MT	10,000	15	46	4PS	3/8	10 @ 1800	37"	66 1/4"	11 1/4"	1575
FA12-1010-MT	12,000	10	10	4PS	7/16	7 1/2 @ 1200	37"	28 3/4"	2 3/4"	1200
FA12-1017-MT	12,000	10	17	4PS	7/16	7 1/2 @ 1200	37"	36 1/4"	4 1/2"	1275
FA12-1024-MT	12,000	10	24	4PS	7/16	7 1/2 @ 1200	37"	43 3/4"	6 1/4"	1350
FA12-1031-MT	12,000	10	31	4PS	7/16	7 1/2 @ 1200	37"	51 1/4"	7 7/8"	1425
FA12-1517-MT	12,000	15	17	4PS	7/16	10 @ 1800	37"	36 1/4"	4 1/2"	1275
FA12-1524-MT	12,000	15	24	4PS	7/16	10 @ 1800	37"	43 3/4"	6 1/4"	1350
FA12-1531-MT	12,000	15	31	4PS	7/16	10 @ 1800	37"	51 1/4"	7 7/8"	1425
FA12-1539-MT	12,000	15	39	4PS	7/16	10 @ 1800	37"	58 3/4"	9 5/8"	1500
FA15-1019-MT	15,000	10	19	4PS	7/16	7 1/2 @ 1200	39"	39 1/4"	4 3/4"	1475
FA15-1025--MT	15,000	10	25	4PS	7/16	7 1/2 @ 1200	39"	46 3/4"	6 3/4"	1550
FA15-1032-MT	15,000	10	32	4PS	7/16	7 1/2 @ 1200	39"	54 1/4"	8 3/8"	1625

COMMON MODELS WITH MOTORIZED TROLLEY (MT) ONLY ABOVE - OTHERWISE BUILD TO ORDER