

STANDARD MONORAIL/BRIDGE DRIVE TRACTORS

SATURN is a trusted source for drive tractors, designed to push/pull rolling loads along monorails. SATURN tractors are built in USA and readily available. Primarily used to motorize manual bridge cranes and trolley hoists, SATURN tractors are a great option when old trolley drives breakdown & parts are not available or too expensive.

SATURN offers 3 Tractor **MODELS** that cover a very wide range of capacity, speed and service requirements.

- **T-144** (Light/Medium Duty); BLUE/ORANGE/RED Class Units
- **T-150** (Heavy Duty); BLUE/ORANGE/RED Class Units
- **T-200** (Extra Heavy Duty); CUSTOM BUILT Units - Only

STANDARD FEATURES:

- Capacity Range: 1 Ton to 20 Ton
- Speed Range: 15 FPM to 200 FPM
- Beam Types: W, S or Patented
- Worm Gear Drives
- TEFC/Inverter Ready (5:1) Trolley Motor
- Power Voltages: 230V or 460V-3Ph-60Hz
- Control Voltage: 115V
- NEMA 1 Enclosures (Indoor Service)
- Single Speed Contactor Controls
- Temp. Rating: 10F to 120F
- Factory Balanced
- Adjustable Trolleys
- Straight Tow Bar
- Rubber/Polyurethane Drive Wheels
- Safety Orange Paint
- High Quality Construction



T-144

- STD. Flange Width: 2" to 8"
- Minimum Radius Curve: 4Ft
- CMAA Service: Class C

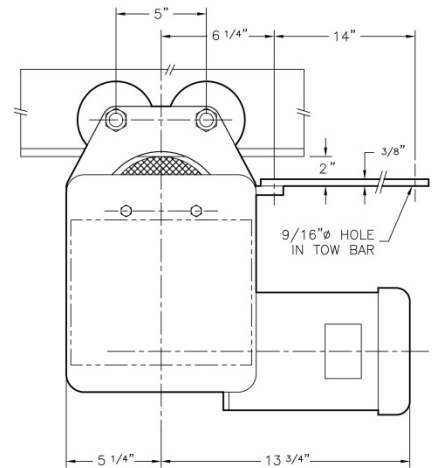
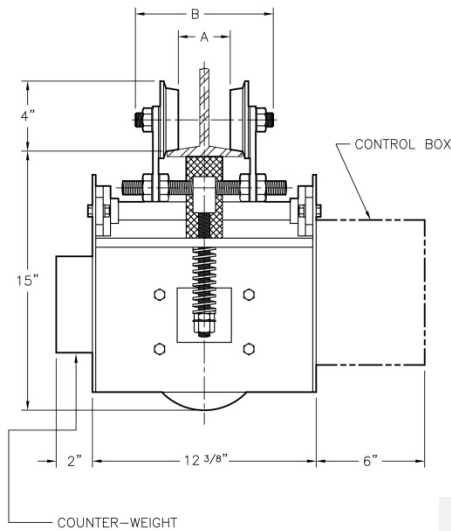

DIMENSIONS FOR REFERENCE

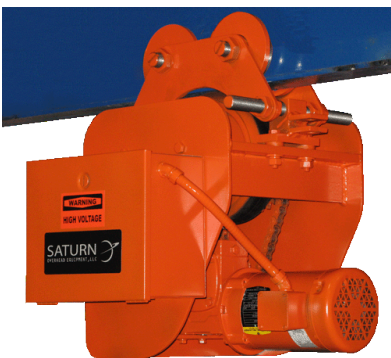

T-150

- STD. Flange Width: 3-1/4" to 10"
- Minimum Radius Curve: 6Ft
- CMAA Service: Class D

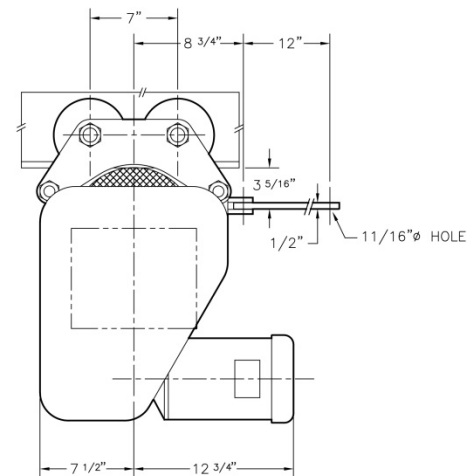
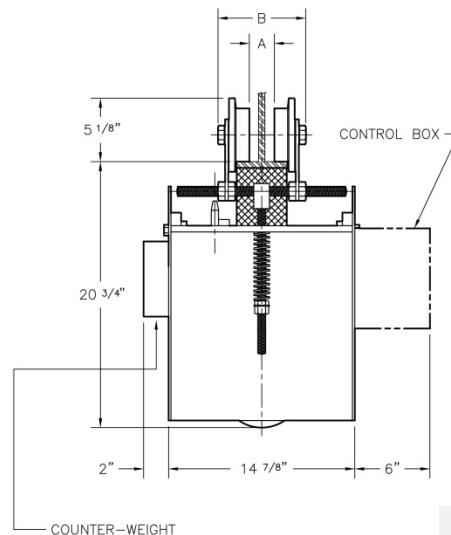

DIMENSIONS FOR REFERENCE