

1/2 TO 1 TON CHAIN HOIST WITH MOTORIZED TROLLEY

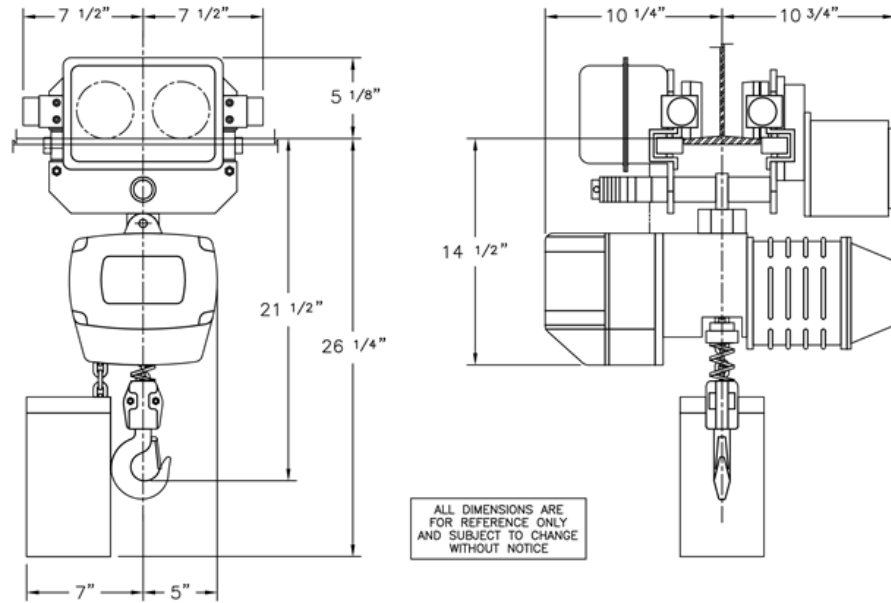

2 TO 3 TON CHAIN HOIST WITH MOTORIZED TROLLEY

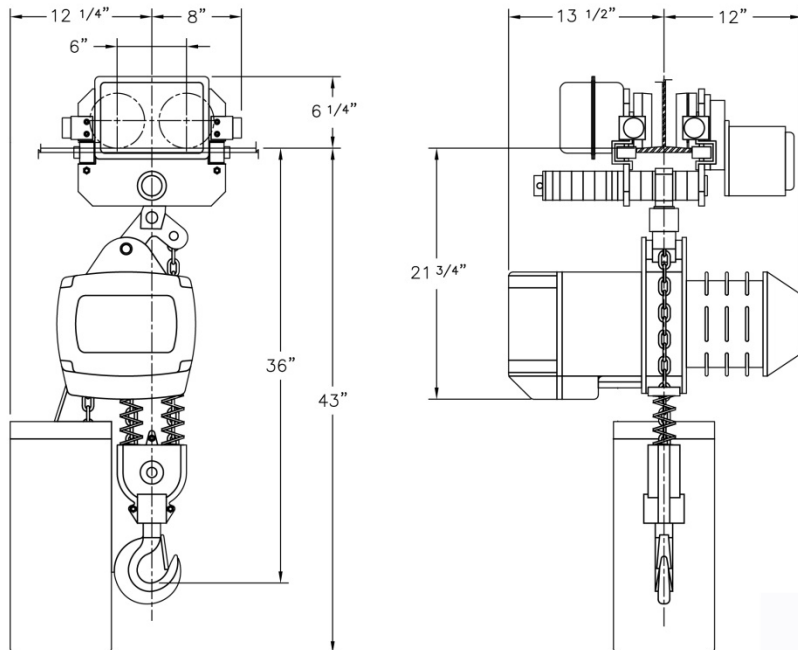

CATALOG NO.	CAPACITY (LBS)	LIFT (FT)	HOIST (FPM)	TROLLEY (FPM)	FLANGE (WIDTH)
USK2-1820-MT2-50	2,000	20	18	50	2.95" - 6.89"
USK6-1720-MT6-50	6,000	20	17	50	3.25" - 6.89"